

Beam direction

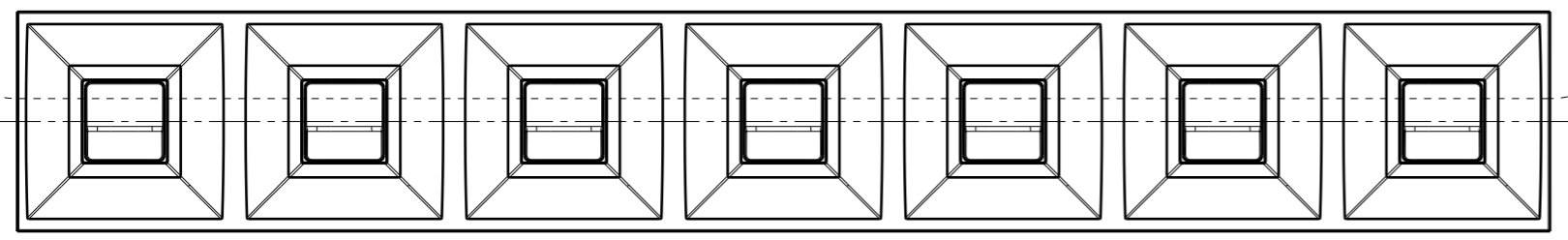

Top view
Scale: 3:4

CN17768_DAISSY-7X1-ZT25-D

COMPONENTS

INDEX	QTY.	PART	TYPE	MATERIAL	COLOR / COATING
1	1	C17767_DAISSY-7X1-ZT25-D	LENS	PMMA	DF21 Diffusive
2	1	SHD	SHADE		
		C16872_DAISSY-7X1-SHD	SHADE	PC/ABS	BLACK/GLOSS
		C17051_DAISSY-7X1-SHD-MATT	SHADE	PC/ABS	BLACK/MATT
		C16876_DAISSY-7X1-SHD-WHT	SHADE	PC	WHITE/GLOSS
		C17225_DAISSY-7X1-SHD-WHT-MATT	SHADE	PC	WHITE/MATT
		C18167_DAISSY-7X1-SHD-MET	SHADE	PC	METAL/GLOSS
		C18409_DAISSY-7X1-SHD-MET-MATT	SHADE	PC	METAL/MATT
		C19763_DAISSY-7X1-SHD-MATT-RED	SHADE	PC	RED/MATT
		C19764_DAISSY-7X1-SHD-MATT-GR	SHADE	PC	GREY/MATT
		C19852_DAISSY-7X1-SHD-MATT-GLD	SHADE	PC	GOLD/MATT

MECHANICAL DRAWING

PRODUCT
DAISSY-7X1



Plastic moulding general tolerances according to DIN 16901-130 and applies if not otherwise shown in the drawing. Silicone moulding general tolerances according to ISO 3302-1 Class M3 and applies if not otherwise shown in the drawing.

FIRST ANGLE PROJECTION:

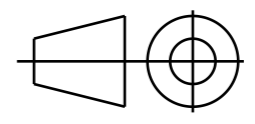

This drawing is the property of LEDiL Oy. It may not be copied or otherwise distributed without prior written permission from LEDiL Oy.

SCALE 1:1

WEIGHT -

A3 SHEET 1/3

Notes

	PCB or heatsink level.
	LED location
	Ensure LED fitting from a product specific 3D model available from www.ledil.com
	For more details about installation please see LEDiL Installation Guide on www.ledil.com

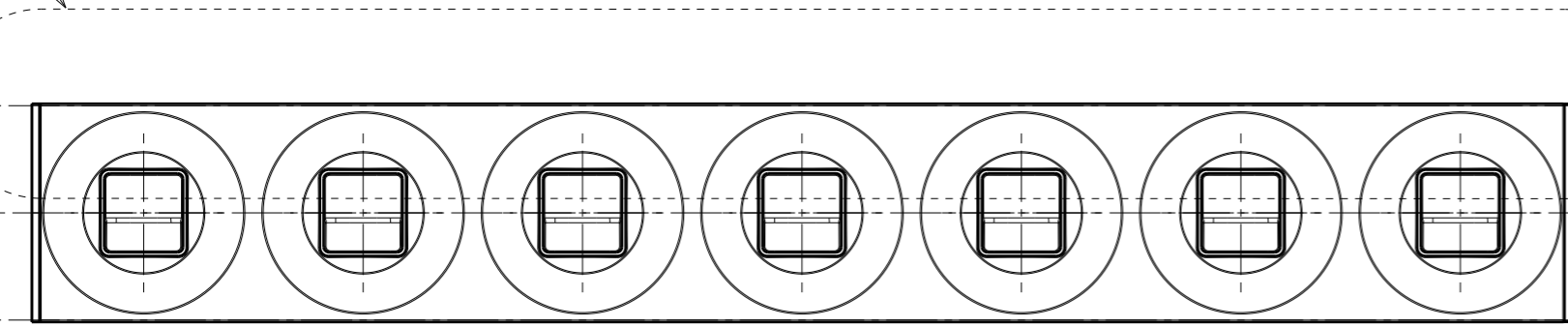
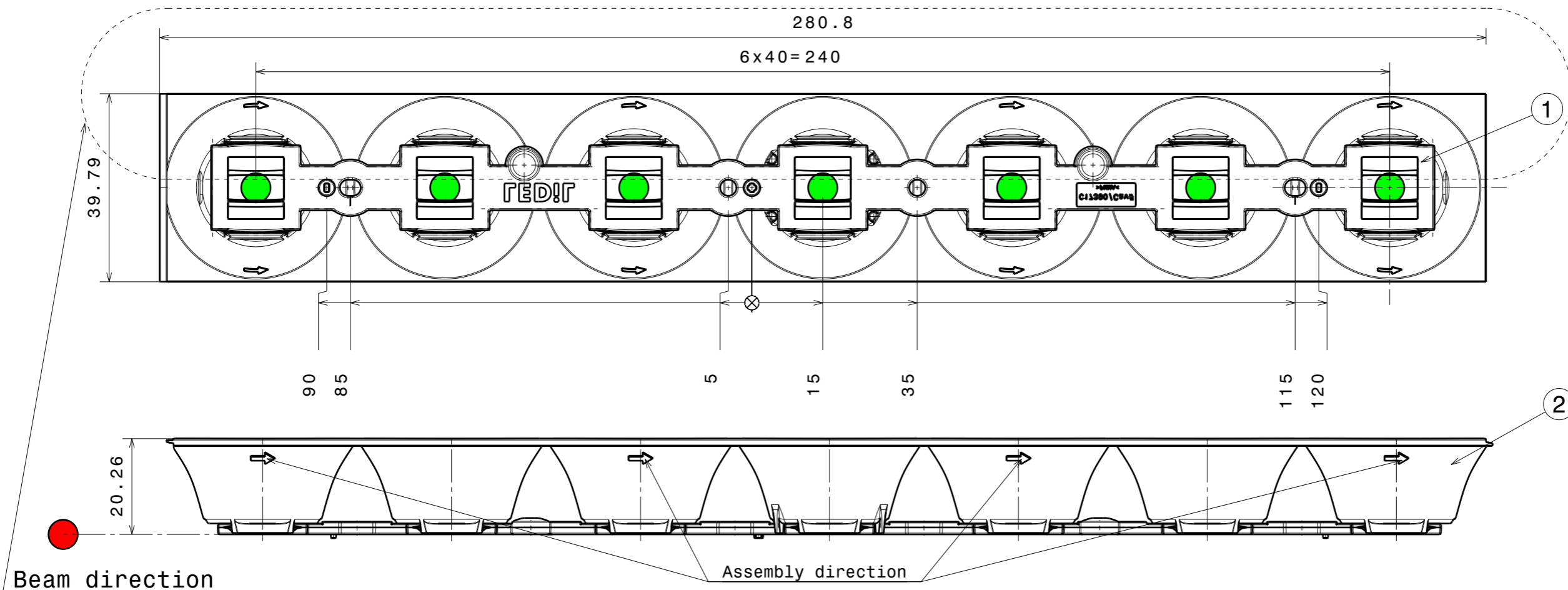

Top view
Scale: 3:4

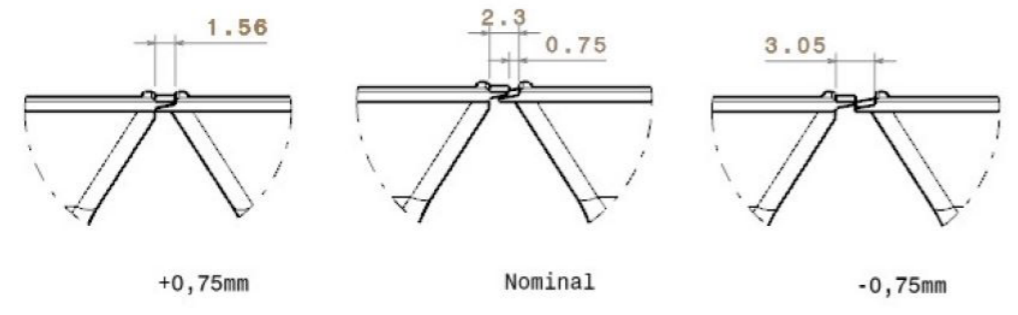

CN17768_DAISSY-7X1-ZT25-D

COMPONENTS

INDEX	QTY.	PART	TYPE	MATERIAL	COLOR / COATING
1	1	C17767_DAISSY-7X1-ZT25-D	LENS	PMMA	DF21 Diffusive
2	1	SHD3	SHADE		
		C19312_DAISSY-7X1-SHD3	SHADE	PC	BLACK/GLOSS
		C19313_DAISSY-7X1-SHD3-MATT	SHADE	PC/ABS	BLACK/MATT
		C19314_DAISSY-7X1-SHD3-WHT	SHADE	PC	WHITE/GLOSS
		C19315_DAISSY-7X1-SHD3-WHT-MATT	SHADE	PC	WHITE/MATT
		C19641_DAISSY-7X1-SHD3-MET	SHADE	PC	METAL/GLOSS
		C19642_DAISSY-7X1-SHD3-MET-MATT	SHADE	PC/ABS	METAL/MATT
		C19853_DAISSY-7X1-SHD3-MATT-GR	SHADE	PC	GREY/MATT
		C19854_DAISSY-7X1-SHD3-MATT-RED	SHADE	PC	RED/MATT
		C19855_DAISSY-7X1-SHD3-MATT-GLD	SHADE	PC	GOLD/MATT

MECHANICAL DRAWING

PRODUCT
DAISSY-7X1



Plastic moulding general tolerances according to DIN 16901-130 and applies if not otherwise shown in the drawing. Silicone moulding general tolerances according to ISO 3302-1 Class M3 and applies if not otherwise shown in the drawing.

FIRST ANGLE PROJECTION:

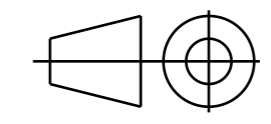

This drawing is the property of LEDiL Oy. It may not be copied or otherwise distributed without prior written permission from LEDiL Oy.

SCALE 1:1

WEIGHT -

A3 SHEET 2/3

- Notes**
- PCB or heatsink level.
 - LED location
 - Ensure LED fitting from a product specific 3D model available from www.ledil.com
 - For more details about installation please see LEDiL Installation Guide on www.ledil.com

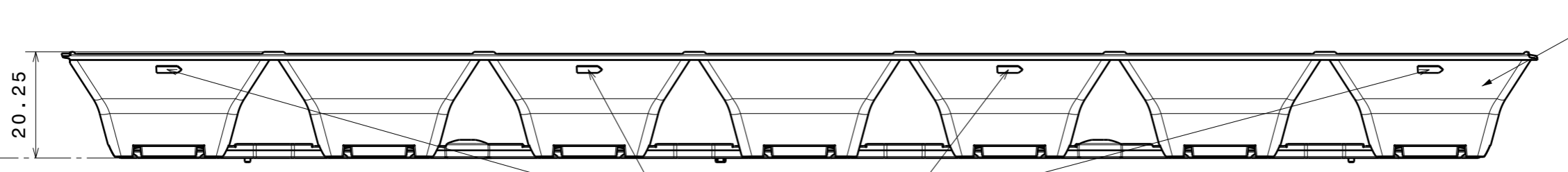
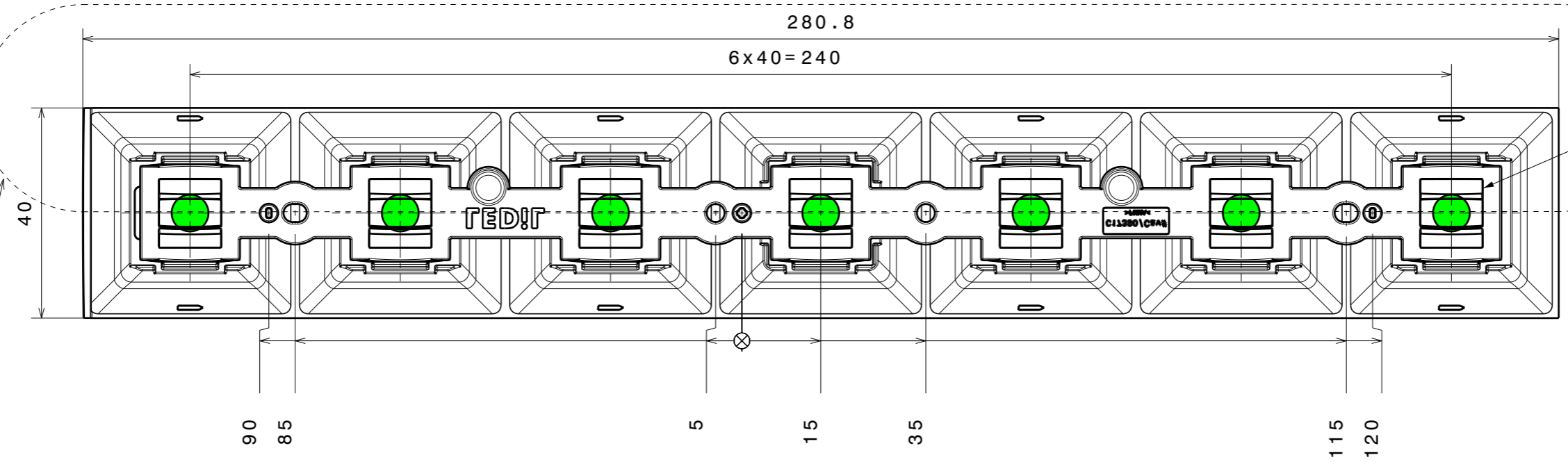

Beam direction

Assembly direction

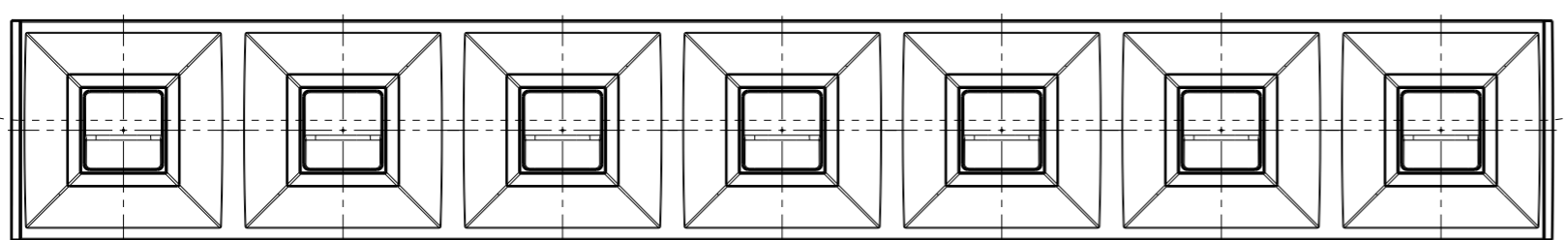

Top view
Scale: 3:4

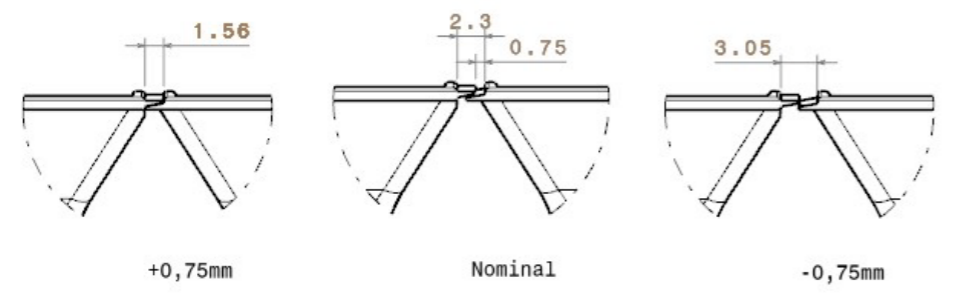

CN17768_DAISY-7X1-ZT25-D

COMPONENTS

INDEX	QTY.	PART	TYPE	MATERIAL	COLOR / COATING
1	1	C17767_DAISY-7X1-ZT25-D	LENS	PMMA	DF21 Diffusive
2	1	SHD2	SHADE		
		L20010_DAISY-7X1-SHD2	SHADE	PC	BLACK/GLOSS
		L20011_DAISY-7X1-SHD2-MATT	SHADE	PC/ABS	BLACK/MATT
		L20012_DAISY-7X1-SHD2-WHT	SHADE	PC	WHITE/GLOSS
		L20013_DAISY-7X1-SHD2-MATT-WHT	SHADE	PC	WHITE/MATT
		L20014_DAISY-7X1-SHD2-MET	SHADE	PC	METAL/GLOSS
		L20015_DAISY-7X1-SHD2-MET-MATT	SHADE	PC/ABS	METAL/MATT

MECHANICAL DRAWING		LEDiL®
PRODUCT DAISY-7X1		
Plastic moulding general tolerances according to DIN 16901-130 and applies if not otherwise shown in the drawing. Silicone moulding general tolerances according to ISO 3302-1 Class M3 and applies if not otherwise shown in the drawing.		FIRST ANGLE PROJECTION:
SCALE 1:1	WEIGHT -	This drawing is the property of LEDiL Oy. It may not be copied or otherwise distributed without prior written permission from LEDiL Oy.
		A3 SHEET 3/3

Notes

- PCB or heatsink level.
- LED location
- Ensure LED fitting from a product specific 3D model available from www.ledil.com
- For more details about installation please see LEDiL Installation Guide on www.ledil.com