

Top view
Scale: 3:4

CN17765_DAISSY-7X1-M

COMPONENTS

INDEX	QTY.	PART	TYPE	MATERIAL	COLOR / COATING
1	1	C17389_DAISSY-7X1-M	LENS	PMMA	clear
2	1	SHD	SHADE		
		C16872_DAISSY-7X1-SHD	SHADE	PC/ABS	BLACK/GLOSS
		C17051_DAISSY-7X1-SHD-MATT	SHADE	PC/ABS	BLACK/MATT
		C16876_DAISSY-7X1-SHD-WHT	SHADE	PC	WHITE/GLOSS
		C17225_DAISSY-7X1-SHD-WHT-MATT	SHADE	PC	WHITE/MATT
		C18167_DAISSY-7X1-SHD-MET	SHADE	PC	METAL/GLOSS
		C18409_DAISSY-7X1-SHD-MET-MATT	SHADE	PC	METAL/MATT
		C19312_DAISSY-7X1-SHD3	SHADE	PC	BLACK/GLOSS
		C19313_DAISSY-7X1-SHD3-MATT	SHADE	PC/ABS	BLACK/MATT
		C19314_DAISSY-7X1-SHD3-WHT	SHADE	PC	WHITE/GLOSS
		C19315_DAISSY-7X1-SHD3-WHT-MATT	SHADE	PC	WHITE/MATT
		C19641_DAISSY-7X1-SHD3-MET	SHADE	PC	METAL/GLOSS
		C19642_DAISSY-7X1-SHD3-MET-MATT	SHADE	PC/ABS	METAL/MATT

MECHANICAL DRAWING		LEDiL [®]
PRODUCT DAISSY-7X1		
Plastic moulding general tolerances according to DIN 16901-130 and applies if not otherwise shown in the drawing. Silicone moulding general tolerances according to ISO 3302-1 Class M3 and applies if not otherwise shown in the drawing.	FIRST ANGLE PROJECTION: 	This drawing is the property of LEDiL Oy. It may not be copied or otherwise distributed without prior written permission from LEDiL Oy.
SCALE 1:1	WEIGHT -	A3 SHEET 1/2

Notes

	PCB or heatsink level.
	LED location
	Ensure LED fitting from a product specific 3D model available from www.ledil.com
	For more details about installation please see LEDiL Installation Guide on www.ledil.com

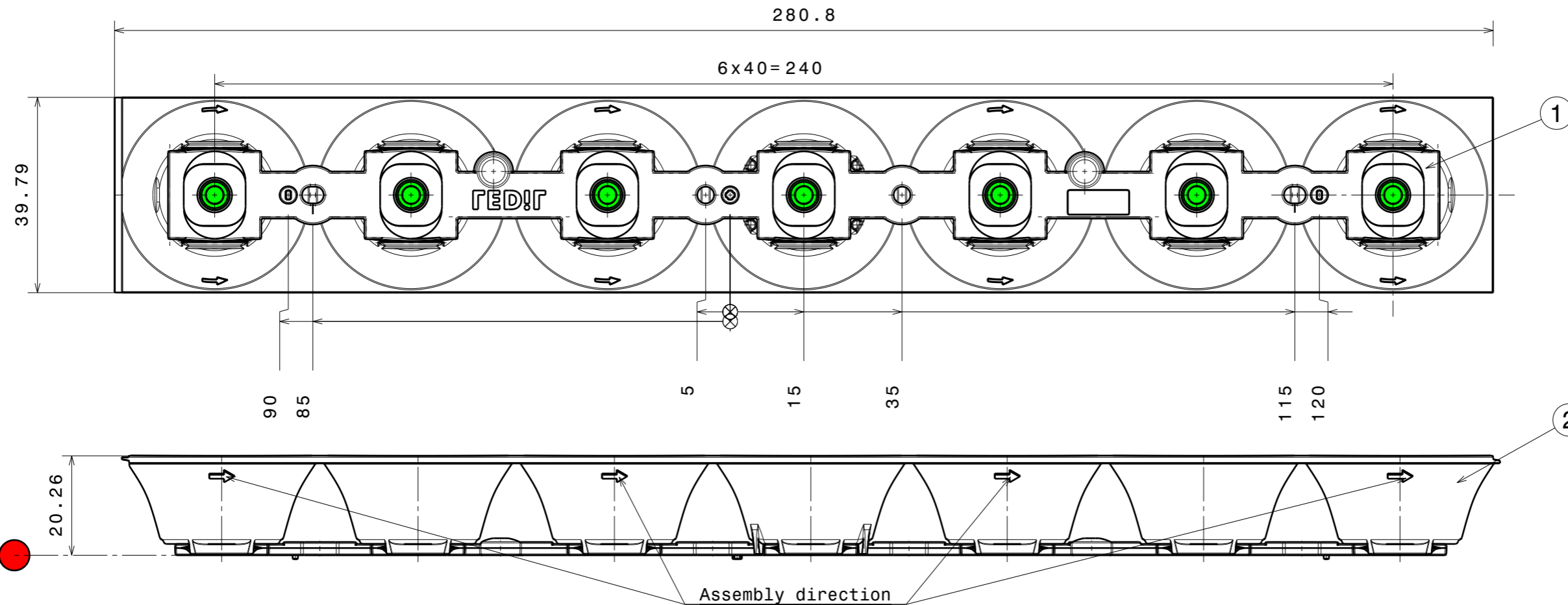

CN17765_DAISSY-7X1-M

COMPONENTS

INDEX	QTY.	PART	TYPE	MATERIAL	COLOR / COATING
1	1	C17389_DAISSY-7X1-M	LENS	PMMA	clear
2	1	SHD	SHADE		
		C16872_DAISSY-7X1-SHD	SHADE	PC/ABS	BLACK/GLOSS
		C17051_DAISSY-7X1-SHD-MATT	SHADE	PC/ABS	BLACK/MATT
		C16876_DAISSY-7X1-SHD-WHT	SHADE	PC	WHITE/GLOSS
		C17225_DAISSY-7X1-SHD-WHT-MATT	SHADE	PC	WHITE/MATT
		C18167_DAISSY-7X1-SHD-MET	SHADE	PC	METAL/GLOSS
		C18409_DAISSY-7X1-SHD-MET-MATT	SHADE	PC	METAL/MATT
		C19312_DAISSY-7X1-SHD3	SHADE	PC	BLACK/GLOSS
		C19313_DAISSY-7X1-SHD3-MATT	SHADE	PC/ABS	BLACK/MATT
		C19314_DAISSY-7X1-SHD3-WHT	SHADE	PC	WHITE/GLOSS
		C19315_DAISSY-7X1-SHD3-WHT-MATT	SHADE	PC	WHITE/MATT
		C19641_DAISSY-7X1-SHD3-MET	SHADE	PC	METAL/GLOSS
		C19642_DAISSY-7X1-SHD3-MET-MATT	SHADE	PC/ABS	METAL/MATT

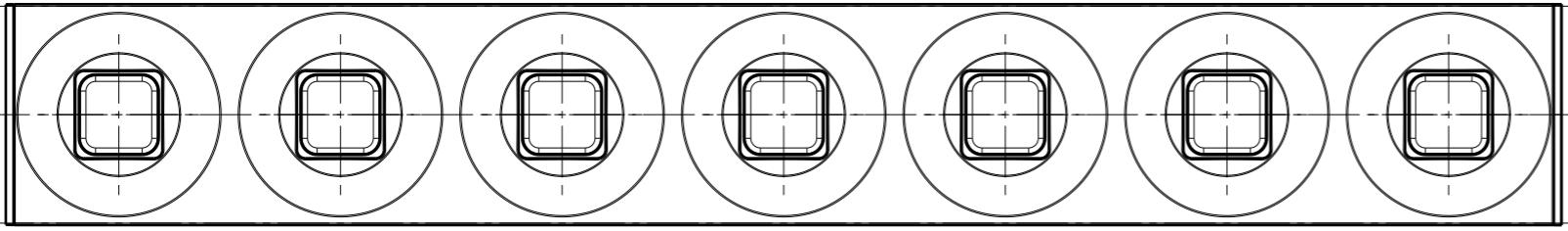

Top view
Scale: 3:4

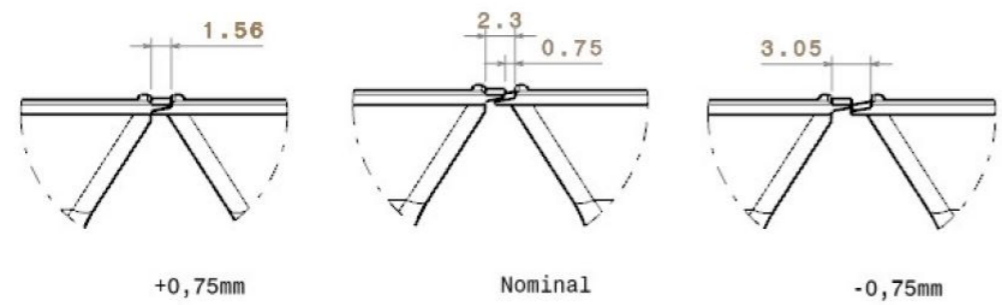

MECHANICAL DRAWING		LEDiL [®]
PRODUCT DAISSY-7X1		
Plastic moulding general tolerances according to DIN 16901-130 and applies if not otherwise shown in the drawing. Silicone moulding general tolerances according to ISO 3302-1 Class M3 and applies if not otherwise shown in the drawing.	FIRST ANGLE PROJECTION: 	This drawing is the property of LEDiL Oy. It may not be copied or otherwise distributed without prior written permission from LEDiL Oy.
SCALE 1:1	WEIGHT -	A3 SHEET 2/2

- Notes**
- PCB or heatsink level.
 - LED location
 - Ensure LED fitting from a product specific 3D model available from www.ledil.com
 - For more details about installation please see LEDiL Installation Guide on www.ledil.com