

Front View
Scale: 3:1

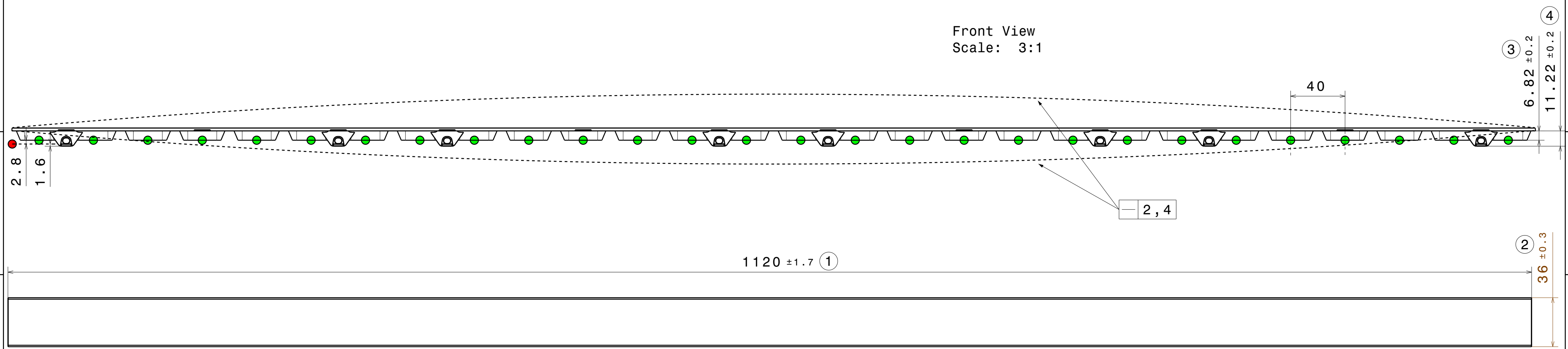

Instructions for handling BRIANNA lenses

Handling of the BRIANNA-14X1 and BRIANNA-28X1

To ensure the linear lens remains intact and to prevent breakage, please follow these instructions carefully:

1. Always use both hands to handle the linear lens.
2. Avoid causing shock impact, bending, or flexing the lens during handling.

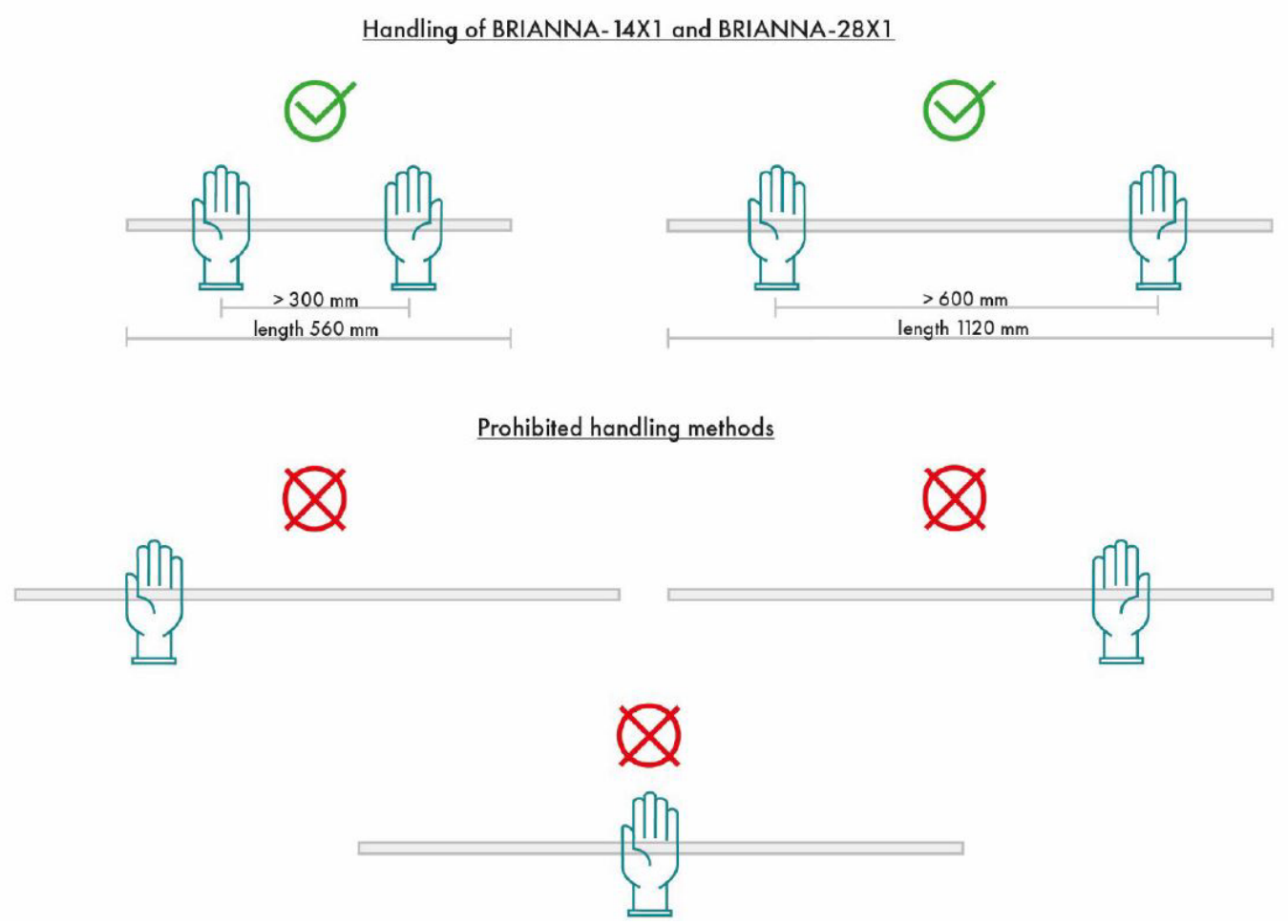

Note: Using BRIANNA-CLIP-A/B will always position lens correctly towards LED/PCB

Notes

- PCB or heatsink level.
- LED location

Ensure LED fitting from a product specific 3D model available from www.ledil.com

For more details about installation please see LEDiL Installation Guide on www.ledil.com

PART	TYPE	MATERIAL	COLOR / COATING
C18343_BRIANNA-28X1-W	LENS	PMMA	clear

MECHANICAL DRAWING		FIRST ANGLE PROJECTION: 	LEDiL This drawing is the property of LEDiL Oy. It may not be copied or otherwise distributed without prior written permission from LEDiL Oy.
PRODUCT	BRIANNA		
SCALE	1:2	WEIGHT	211,8g (31)
		A2	SHEET 1/1

Assembly Example Brianna 28x1 Clip A

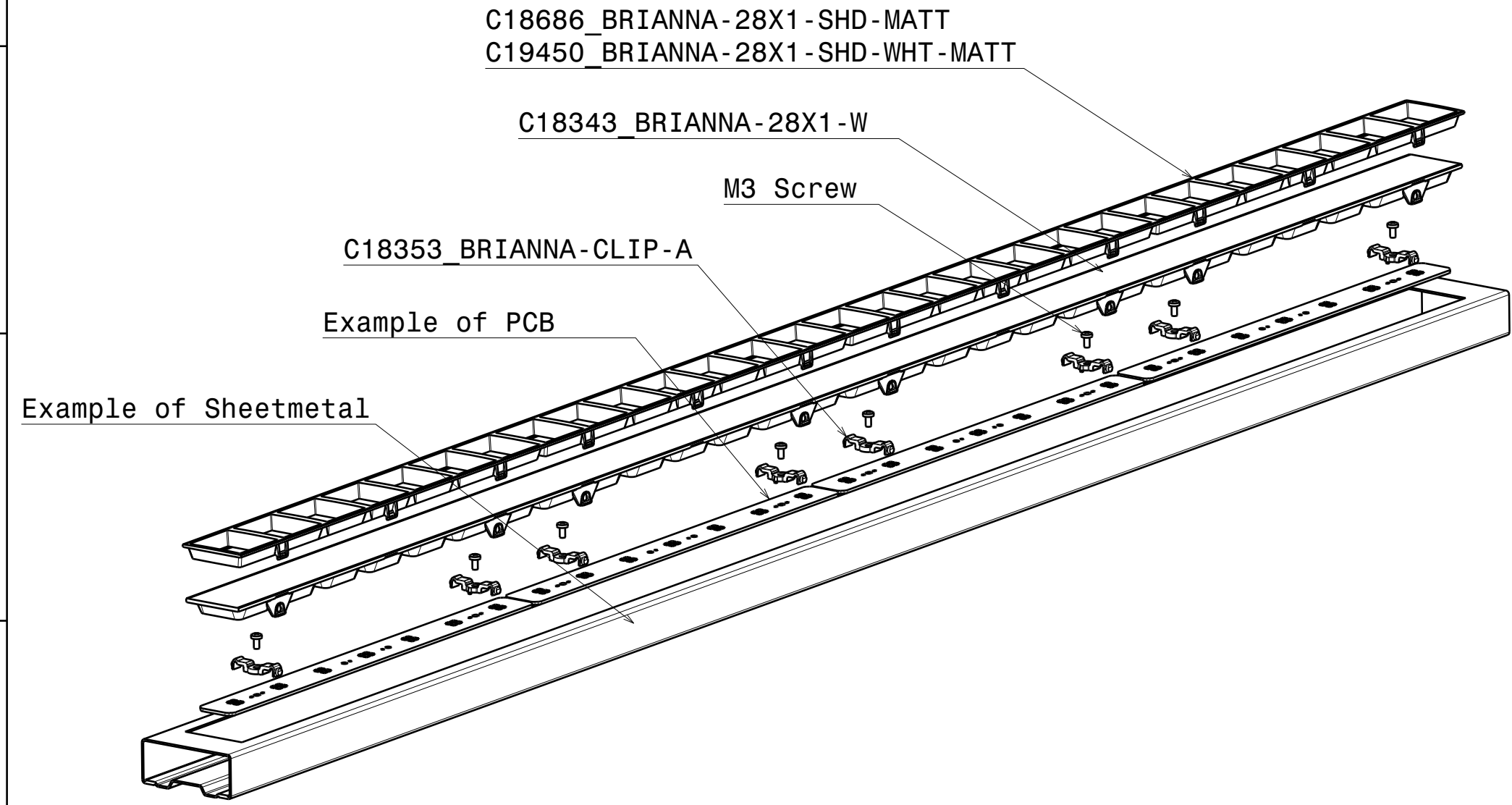

Please Note: If using C18353_BRIANNA-CLIP-A, M3 Screws to be used.

Assembly Example Brianna 28x1 Clip B

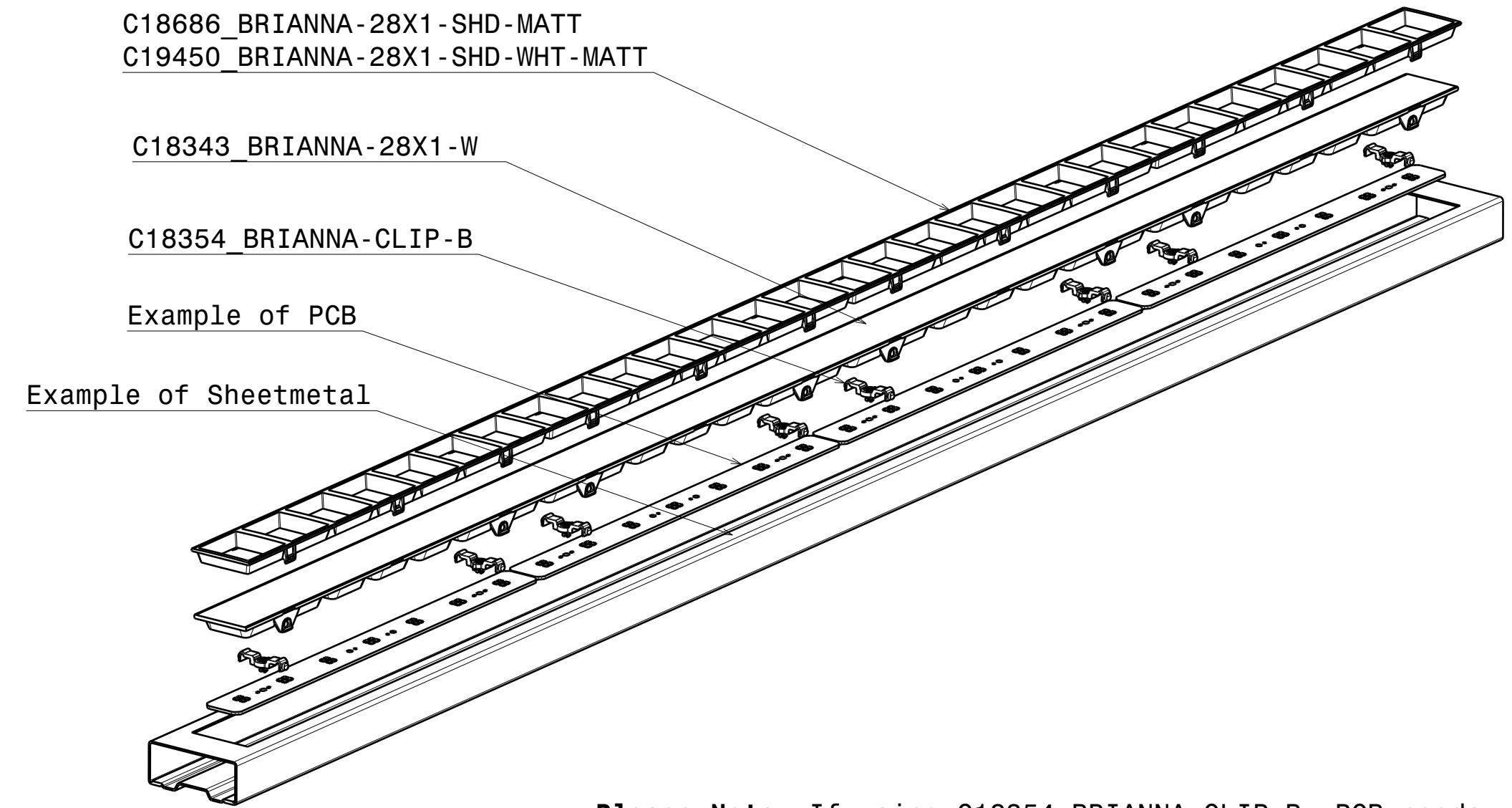

Please Note: If using C18354_BRIANNA-CLIP-B, PCB needs separate fixing to the housing for example screws.

COMPONENTS

PART	TYPE	COUNT	MATERIAL	COLOR / COATING
C18343_BRIANNA-28X1-W	LENS	1	PMMA	clear
C18686_BRIANNA-28X1-SHD-MATT	Accessory	1	PC	black
C19450_BRIANNA-28X1-SHD-WHT-MATT	Accessory	1	PC	white
C18353_BRIANNA-CLIP-A	Accessory	8	PC	clear
C18354_BRIANNA-CLIP-B	Accessory	8	PC	clear
Example PCB	PCB	4		
Example Sheetmetal	Sheetmetal	1		
M3 Screw	Screw	8		

MECHANICAL DRAWING

PRODUCT

BRIANNA

Plastic moulding general tolerances according to DIN 16901-130 and applies if not otherwise shown in the drawing. Silicone moulding general tolerances according to ISO 3302-1 Class M3 and applies if not otherwise shown in the drawing.

FIRST ANGLE PROJECTION:

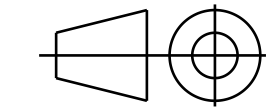

LEDiL

This drawing is the property of LEDiL Oy. It may not be copied or otherwise distributed without prior written permission from LEDiL Oy.

SCALE 1:3

WEIGHT

A2 SHEET 1/1

Notes

●	PCB or heatsink level.
●	LED location
Ensure LED fitting from a product specific 3D model available from www.ledil.com	
For more details about installation please see LEDiL Installation Guide on www.ledil.com	