

CP19786_AMY-110-WAS-C
CP19787_AMY-110-WAS-C-WHT

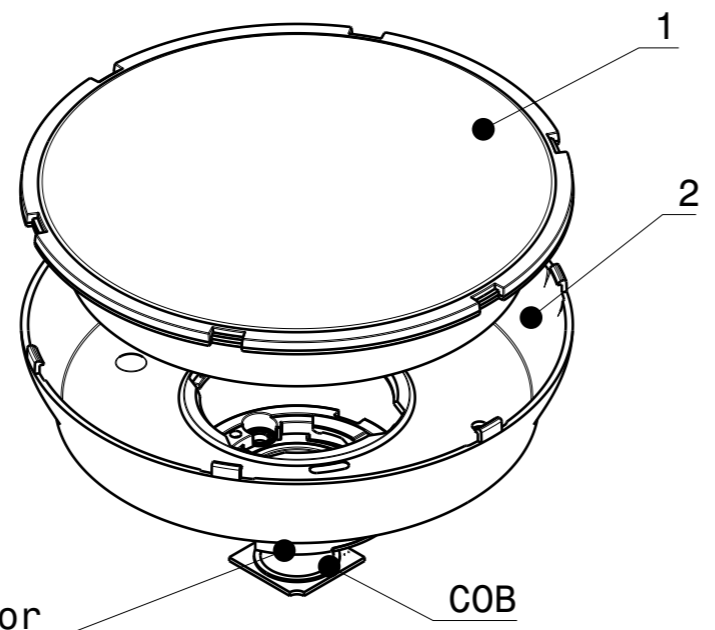

HEKLA Connector
COB

CP19788_AMY-110-WAS-B
CP19789_AMY-110-WAS-B-WHT

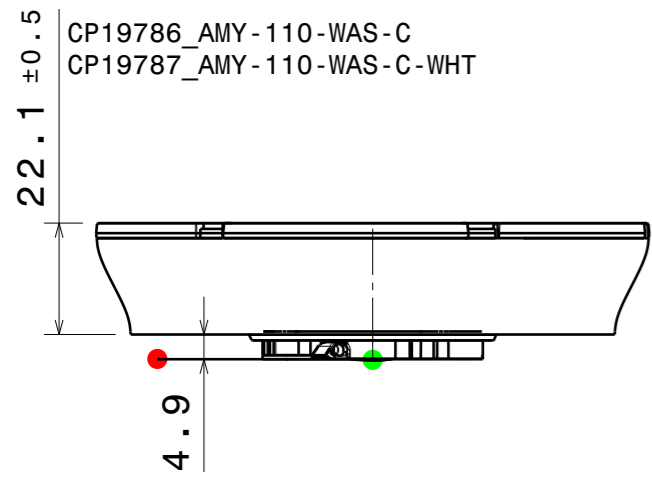
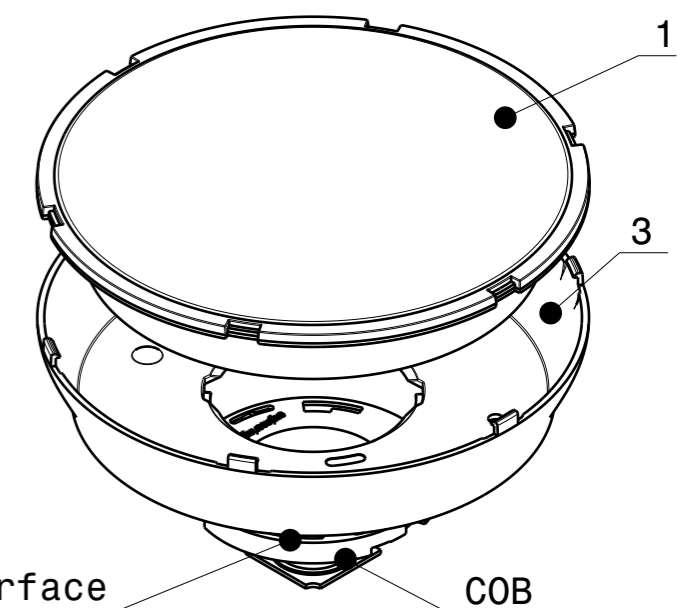
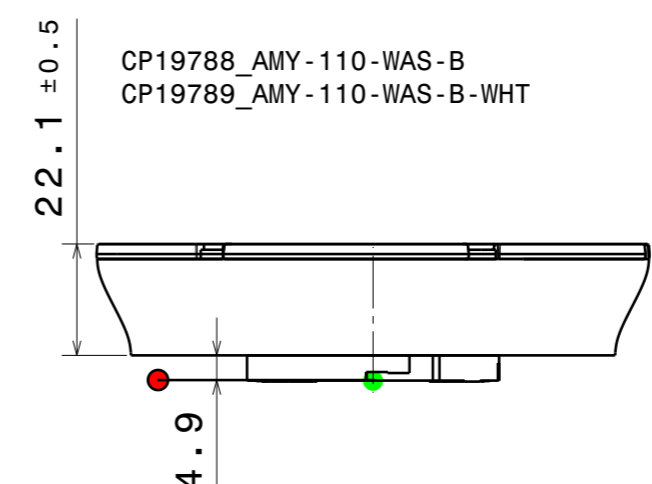

Connector
BJB / B+W 35mm-interface
COB

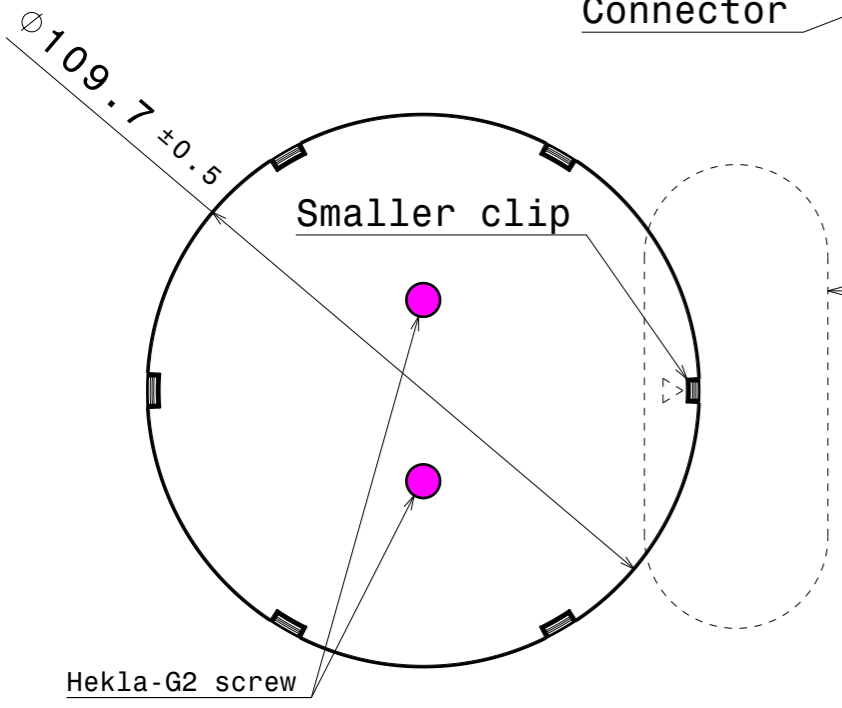

Beam direction: smaller clip is on the wall side as beam direction indicator.

INDEX	PART	TYPE	QTY	MATERIAL	COLOUR/COATING	ASSEMBLY CODES
1	AMY-110-WAS	LENS	1			
	C19785_AMY-110-WAS			PMMA	CLEAR	
2	HOLDER C	HOLDER	1			
	C18556_AMY-110-HLD-C			PC	BLACK	CP19786_AMY-110-WAS-C
	C18939_AMY-110-HLD-C-WHT			PC	WHITE	CP19787_AMY-110-WAS-C-WHT
3	HOLDER B					
	C18571_AMY-110-HLD-B			PC	BLACK	CP19788_AMY-110-WAS-B
	C18940_AMY-110-HLD-B-WHT			PC	WHITE	CP19789_AMY-110-WAS-B-WHT

MECHANICAL DRAWING

PRODUCT
AMY-110-WAS



Plastic moulding general tolerances according to DIN 16901-130 and applies if not otherwise shown in the drawing. Silicone moulding general tolerances according to ISO 3302-1 Class M3 and applies if not otherwise shown in the drawing.

FIRST ANGLE PROJECTION:

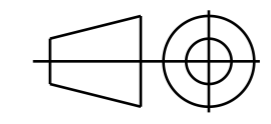

This drawing is the property of LEDiL Oy. It may not be copied or otherwise distributed without prior written permission from LEDiL Oy.

SCALE 2:3

WEIGHT -

A3 SHEET 1/2

Notes

	PCB or heatsink level.
	LED location
	Ensure LED fitting from a product specific 3D model available from www.ledil.com
	For more details about installation please see LEDiL Installation Guide on www.ledil.com

H G F E D C B A

4

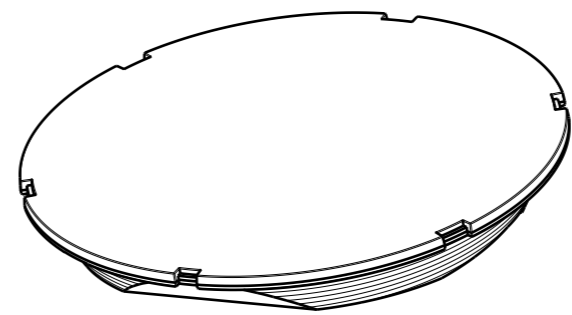
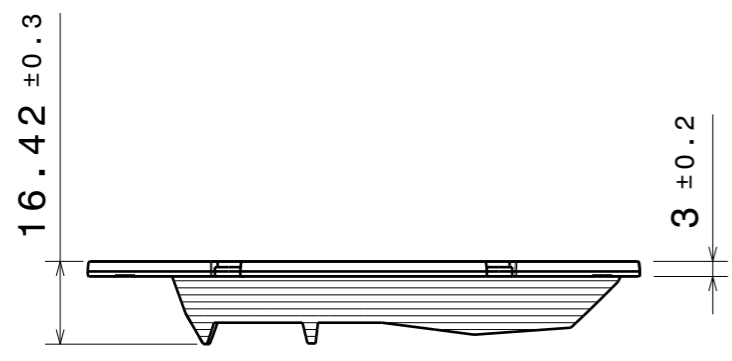

3

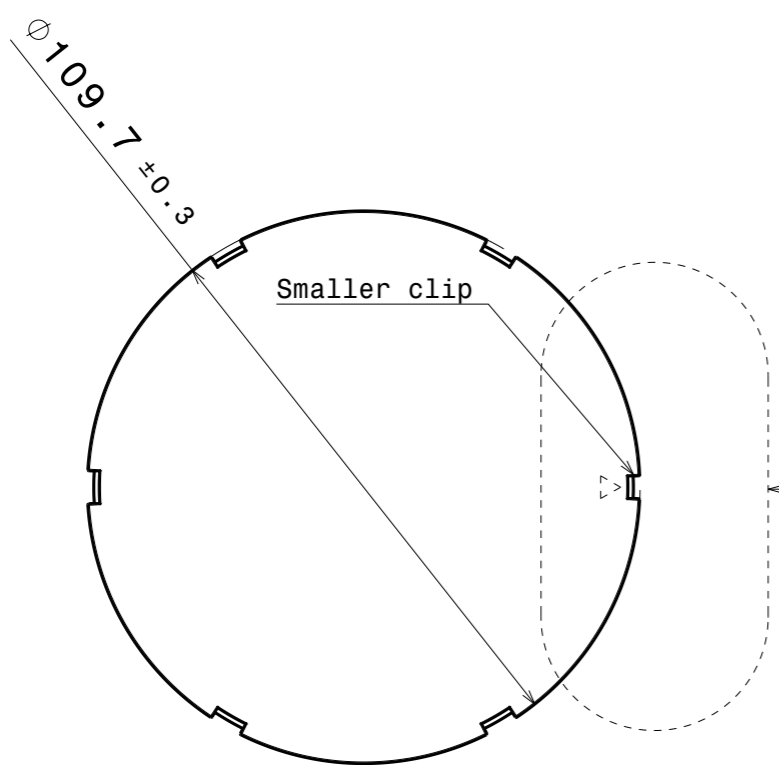

Beam direction: smaller clip is on the wall side as beam direction indicator.

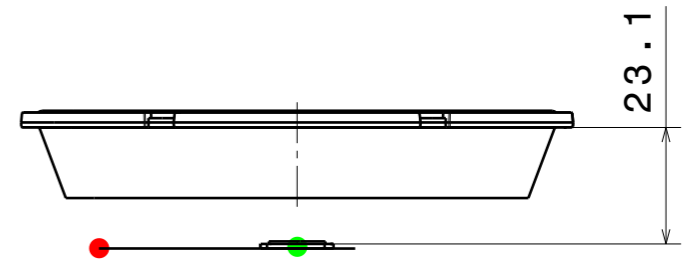

2

PART	TYPE	MATERIAL	COLOR / COATING
C19785_AMY-110-WAS	LENS	PMMA	CLEAR

MECHANICAL DRAWING

PRODUCT **AMY-110-WAS**

LEDiL

Plastic moulding general tolerances according to DIN 16901-130 and applies if not otherwise shown in the drawing. Silicone moulding general tolerances according to ISO 3302-1 Class M3 and applies if not otherwise shown in the drawing.

FIRST ANGLE PROJECTION:

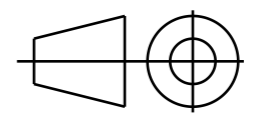

This drawing is the property of LEDiL Oy. It may not be copied or otherwise distributed without prior written permission from LEDiL Oy.

SCALE	2:3	WEIGHT	-	A3	SHEET 2/2
-------	-----	--------	---	----	-----------

Notes

- PCB or heatsink level.
- LED location
- Ensure LED fitting from a product specific 3D model available from www.ledil.com
- For more details about installation please see LEDiL Installation Guide on www.ledil.com

H G F E D C B A

4

3

2

1