

REV	DATE
001	04.02.2025

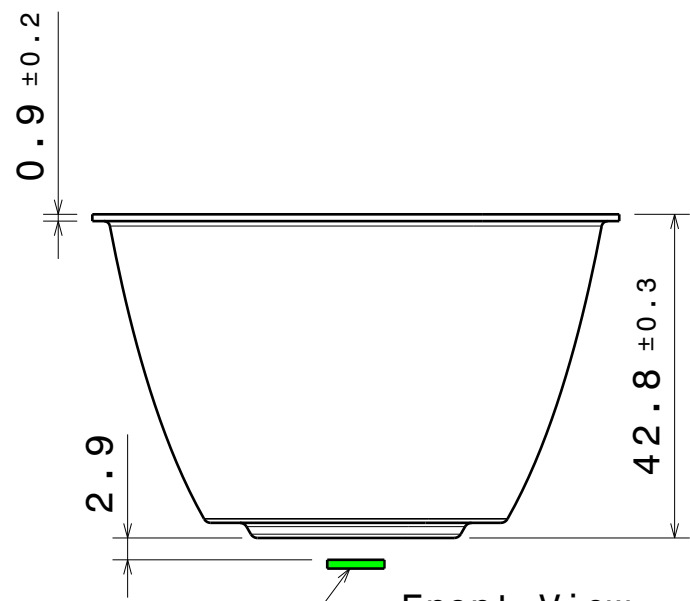

Front View
Scale: 1:1

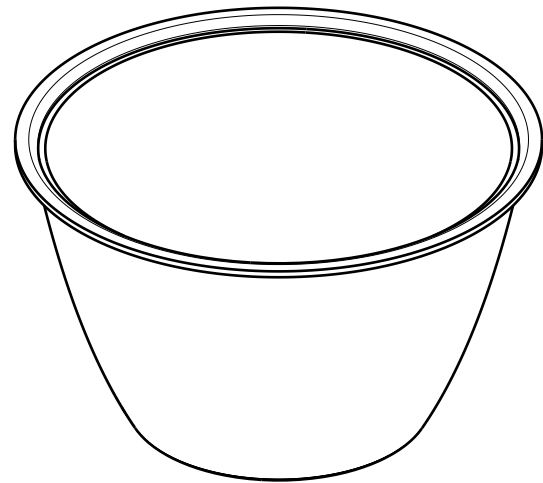

Isometric View
Scale: 1:1

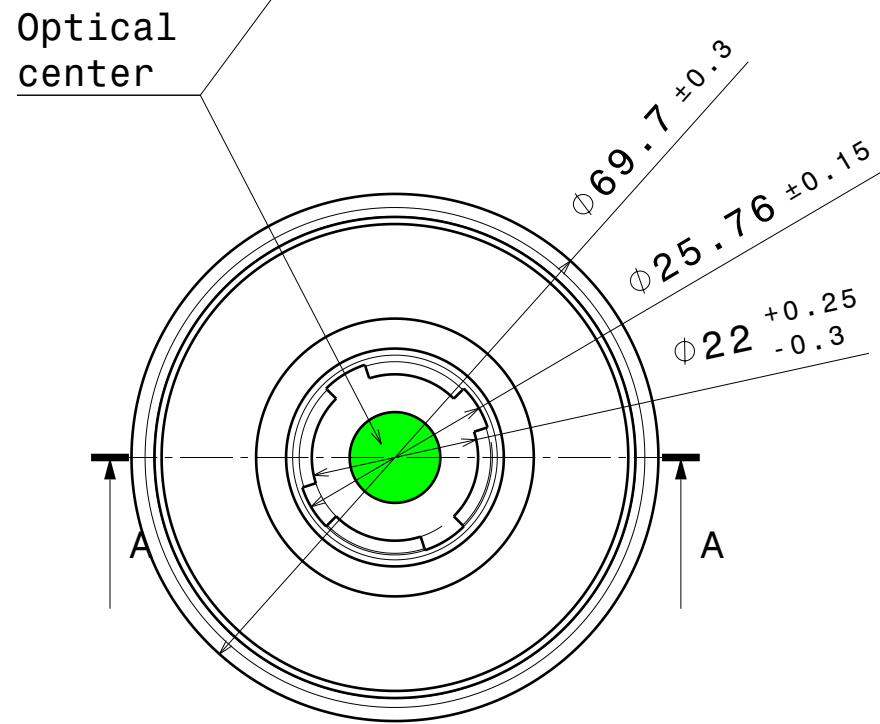

Top View
Scale: 1:1

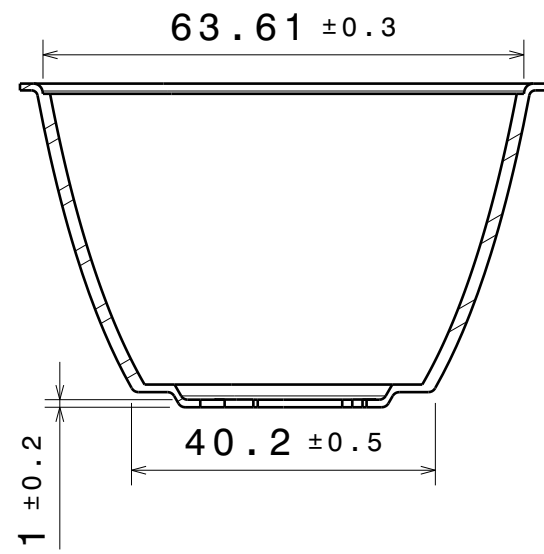

Section view A-A
Scale: 1:1

Example assembly with Hekla socket:

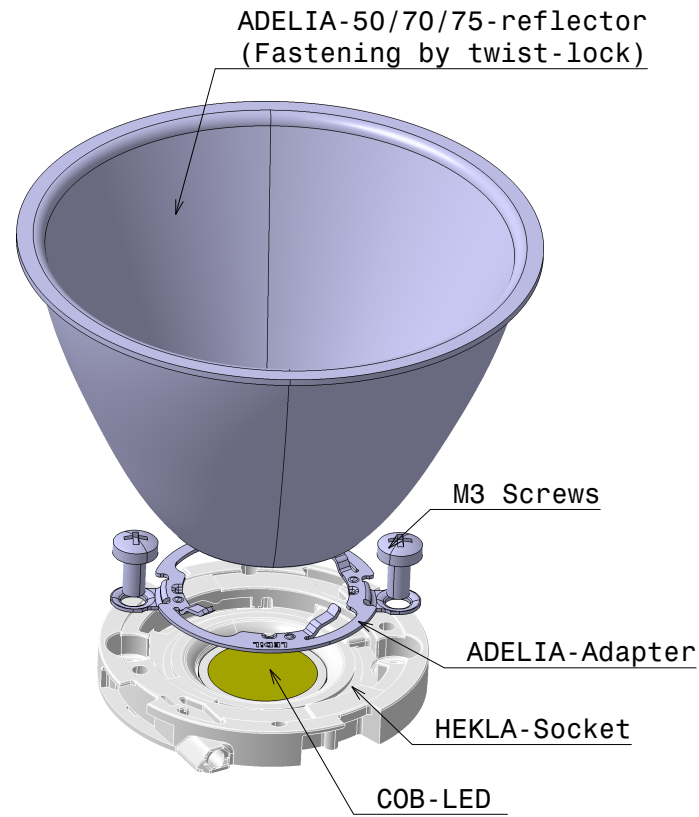

Example assembly with slim Ø 35mm BJB socket:

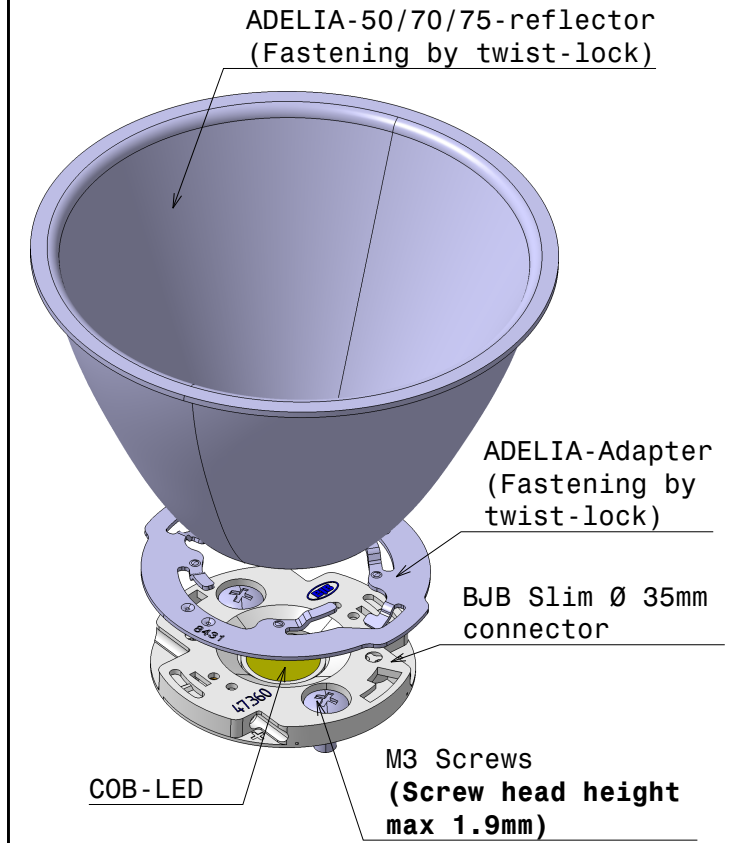

PART	TYPE	MATERIAL	COLOR / COATING
C19523_ADELIA-70-W2	REFLECTOR	aluminium	polished

MECHANICAL DRAWING

PRODUCT
ADELIA-70-W2

Plastic moulding general tolerances according to DIN 16901-130 and applies if not otherwise shown in the drawing. Silicone moulding general tolerances according to ISO 3302-1 Class M3 and applies if not otherwise shown in the drawing.

FIRST ANGLE PROJECTION:

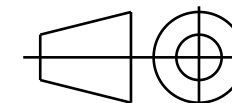

LEDiL

This drawing is the property of LEDiL Oy. It may not be copied or otherwise distributed without prior written permission from LEDiL Oy.

SCALE 1:1

WEIGHT -

A3 SHEET 1/1

Notes

- LED location
- Ensure LED fitting from a product specific 3D model available from www.ledil.com
- For more details about installation please see LEDiL Installation Guide on www.ledil.com